

DAVID
LENK

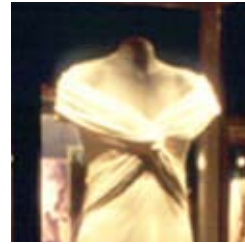
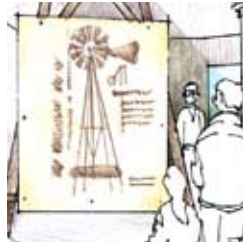

CONCEPTUAL
PLANNER

EXHIBITION
DESIGNER

S E L E C T E D C L I E N T L I S T

The Mariner's Museum	Louisiana State Museum
The Smithsonian Institution	The Peoples Princess Charitable Foundation
Homestead National Monument of America	The Austin Healey Museum
Centers for Disease Control and Prevention	Wheeling National Heritage Area Corporation
U.S. Army Corps of Engineers	Historic Annapolis Foundation
Martha Berry College	National Cancer Institute
Nauticus	Ships of the Sea
The Jewish Children's Museum	Historic London Town

DAVID
LENK

**Conceptual Planner
Exhibition Designer**

A personal passion for history, 3-D design and story telling drives my work as a planner, content developer and interpretive designer.

With every project, I strive for the unity of content and concept. This balance is achieved through a clear understanding of client goals, content, space and visitor expectations.

My extensive fine arts training combines with over 11 years of design and fabrication experience to temper the imaginative with the practical-which guides my conceptual and design development process.

I maintain a network of detailing engineers, fabricators and specialty vendors and offer consultation services for project planning, content development, and art direction.

PROFILE



DAVID LENK

RAYSTOWN LAKE VISITOR CENTER

U.S. Army Corps of Engineers, Hesston,
Pennsylvania

The Raystown Lake Visitor Center conveys the history and ecology of Pennsylvania's largest man-made lake. Electro-mechanical and touch screen interactive activities offer a wide range of information about local attractions, regional history, hydroelectric power generation and dam construction. These features are supported by colorful static exhibit panels and artifacts.

David Lenk was responsible for full concept development, research oversight and graphic art direction. Explus Incorporated fabricated and installed the exhibits.



PORTFOLIO

DAVID LENK

HOMESTEAD VISITOR CENTER, BEATRICE, NEBRASKA

In Progress

Homestead National Monument of
America – National Park Service

The Homestead Act that President Lincoln signed into law in 1862 opened the West to millions and changed America forever. A new visitor center has been designed to offer a fresh interpretation of this epic story. Shown here are preliminary concept sketches and a later graphic layout from the design development currently in process.

Identifying the main themes and distilling this multi-layered story has required close coordination between David, detailing engineer Kevin Brookes, the Park staff, NPS specialists and the script writer.

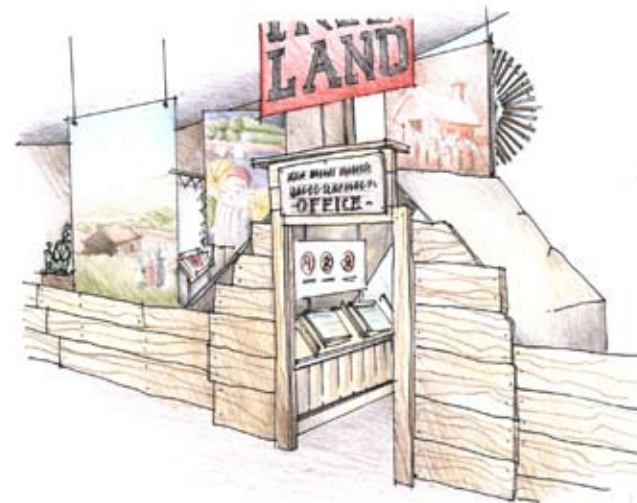
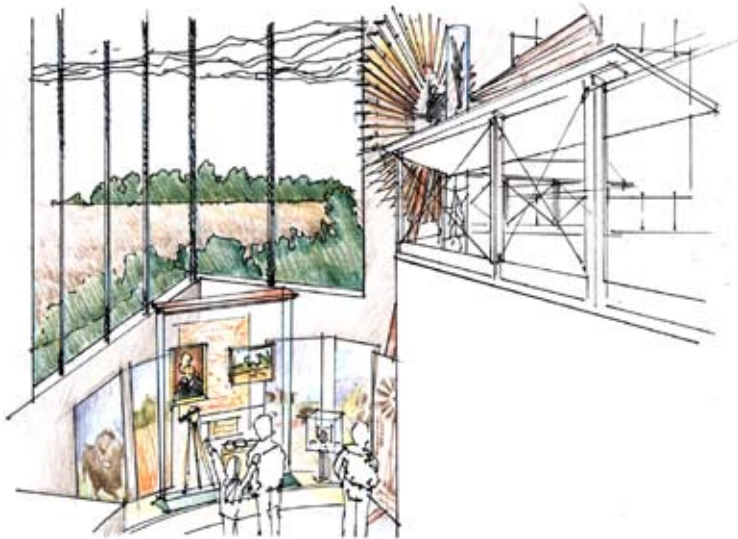

PORTFOLIO



DAVID LENK

WHEELING ARTISAN CENTER

Wheeling National Heritage Area
Corporation

The Wheeling Artisan Center is a 4,500 square foot blend of interpretive exhibits with a retail crafts gallery. The exhibits invite the visitor to explore Wheeling's 19th century manufacturing heritage through the serialized lives of personalities involved with each of its key industries. These exhibits employ a wide range of large and industrial artifacts and products from Wheeling's past in contrast with quality modern-day craft items.

David Lenk developed the foundational interactive concept of this experience and worked closely with WNHAC through the research and artifact selection phases. He further refined the final design based on what industries and representative personalities were chosen as topics. Explus Incorporated fabricated and installed the exhibits.

PORTFOLIO



DAVID LENK

DRESSES FOR HUMANITY

The People's Princess
Charitable Foundation

Dresses for Humanity was a traveling exhibit featuring fourteen gowns that were once worn by the late Princess of Wales. David Lenk was responsible for developing the concept and the final design for this high profile project. The gowns are showcased in elegant steel and acrylic cases, flanked by large format photography. This exhibit toured internationally for several years, raising 22 million dollars for charity.

Explus Incorporated of Dulles, Virginia provided complete fabrication services for this exhibit.

PORTFOLIO



DAVID LENK

MARTHA BERRY MUSEUM

Martha Berry College
Rome, Georgia

This museum celebrates the life of the famed 19th century reformer Martha Berry and the college that now bears her name. Artifacts and photographic images culled from a remarkable archive flow through three chronologically themed galleries, which end in a space exploring Martha Berry College today. Period materials and sets provide evocative backdrops and two touch screen interactive stations which allow for additional in-depth exploration.

David Lenk worked very closely with the museum's curators to develop the storyline based on the existing space. He coordinated architectural modifications required to allow for the creation of four connected galleries. Explus Incorporated fabricated and installed the exhibits.

PORTFOLIO

DAVID LENK

USS MONITOR CENTER

In Progress

Mariners' Museum
Newport News

A 30 million-dollar exhibit and conservation complex is currently under construction on the grounds of the Mariners' Museum. When completed, it will serve as the final berth for key recovered components of the revolutionary Civil War iron clad Monitor. David Lenk has been retained to develop substitute exhibits for the turret and power plant (both under long-term conservation), assist in the development an interactive theatre, revise structures and specific exhibit features from an earlier design concept, and direct the detailing of all exhibit components.

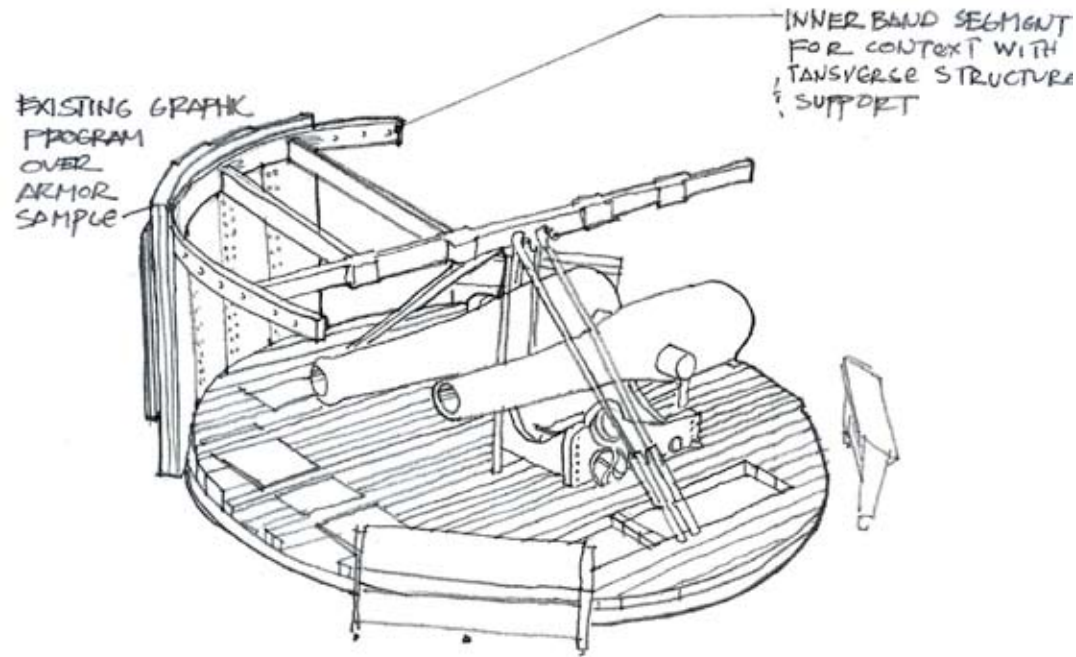

AN EARLY POINT IN TIME ...

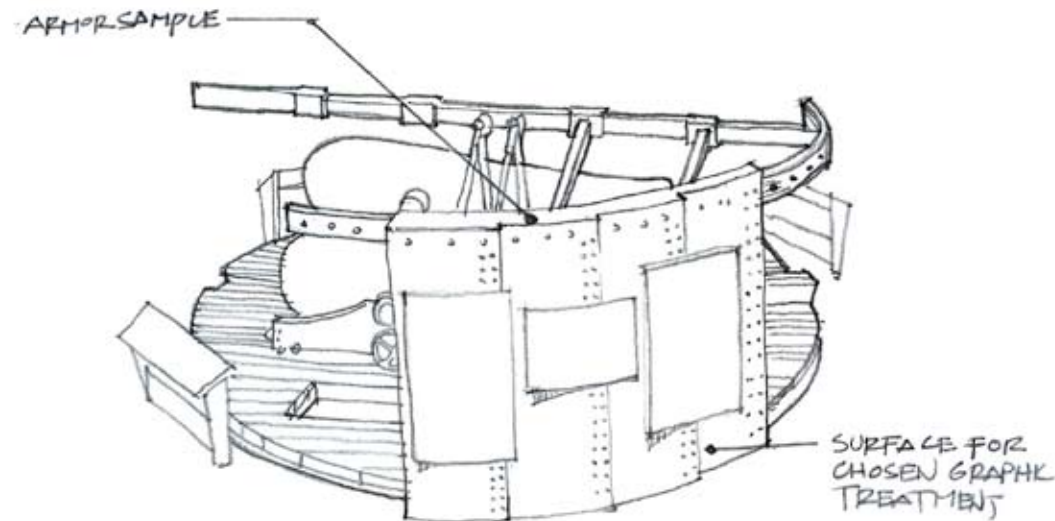

CONCEPT "AS-BUILT" BY SUBSTITUTING ARMOR FOR GYPSUM BACKWALL

PORTFOLIO

DAVID LENK

EXHIBIT PROPOSAL

Independence Hall Foundation
Wheeling, West Virginia

Wheeling's Independence Hall Museum was chosen as the permanent venue for an important collection of conserved regimental banners and standards from the Civil War. David Lenk was asked by the Foundation to propose for both a method to display these flags and series of supporting interpretive exhibits. These digital renderings by Kevin Brookes illustrate David's design and interpretive concept and formed a key part of his final proposal.

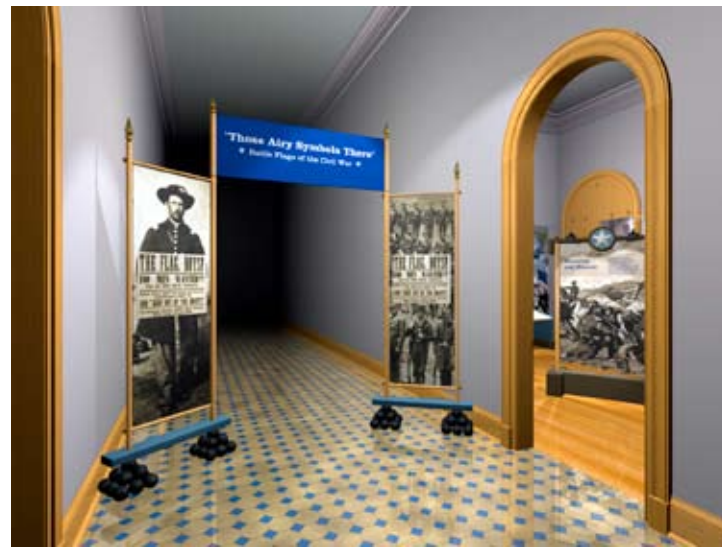
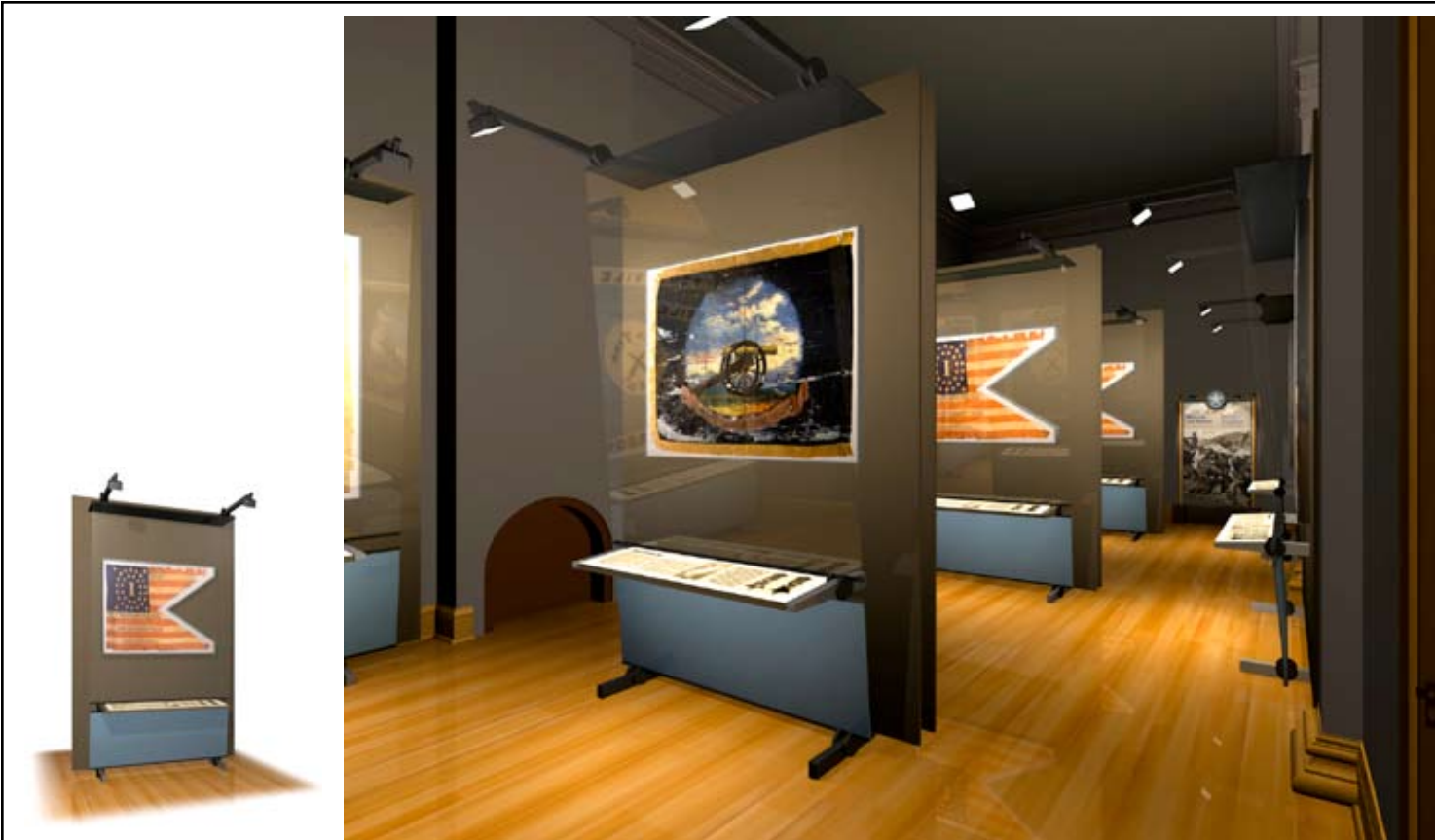

PORTFOLIO



DAVID LENK

TITANIC

Nauticus
Norfolk, Virginia

Nauticus was the venue for the first exhibit of artifacts recovered from the RMS Titanic in the United States. The entire 6000 square foot exhibit was conceived, developed and installed by Explus in ten weeks. This effort required concurrent development of content with case work; the case housing the starboard stern telegraph contained two tons of aqueous solution along with the artifact itself. David Lenk developed the concept, graphics and lighting, designed the modular exhibit furniture, selected images and negotiated use rights, directed the writing of the script and created a storyboard for an A/V presentation.

PORTFOLIO