



All Scales

## Parabellum Machine Gun Assembly Directions





# Step 1

ASSEMBLY DRAWINGS SHOWN AT 1 / 6 SCALE

## Assemble the cooling barrel



- 1** Insert the aluminum tube through the holes and bond in place. Leave 1/2 inch extra tubing at each end to be trimmed as necessary during the final assembly

### Assembly Tip:

Soak the paper in warm water to make rolling the cooling barrels easier. Wrap around a dowel and let dry into shape.

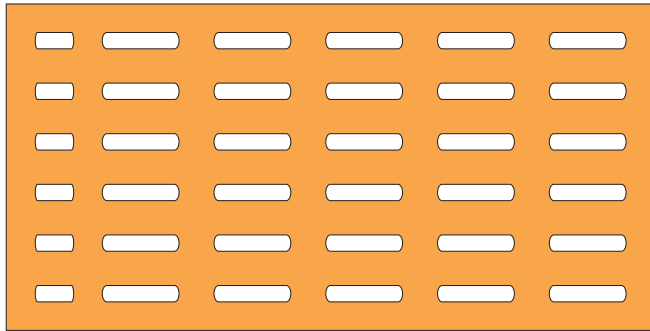

**2**

Roll paper tube around the two end caps and metal tube section. Make sure the seam is centered at the bottom.

Cooling Barrel

Mount outside

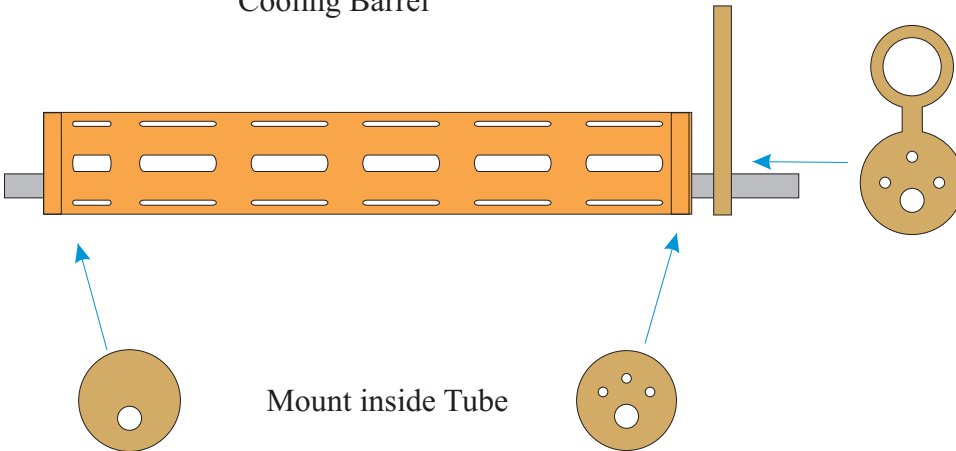

**3** **Detail Note**

Round site can be trimmed off and replaced with rectangle site as shown in the cover sheet photo. Site can be made from brass wire.

**or**

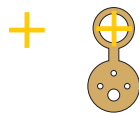

Mount two pieces of wire inside the site ring to simulate the cross hairs.

**4**

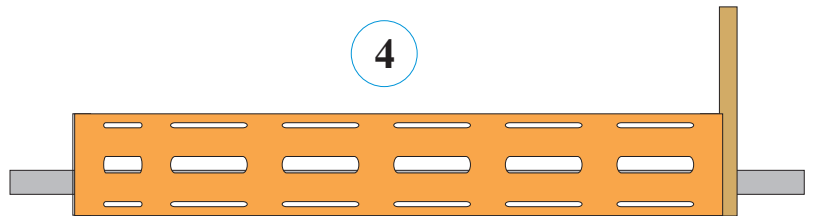

Complete the assembly by lightly sanding all parts and seal with primer or white glue and set aside to dry.

ASSEMBLY DRAWINGS SHOWN AT 1 / 6 SCALE

Right Side

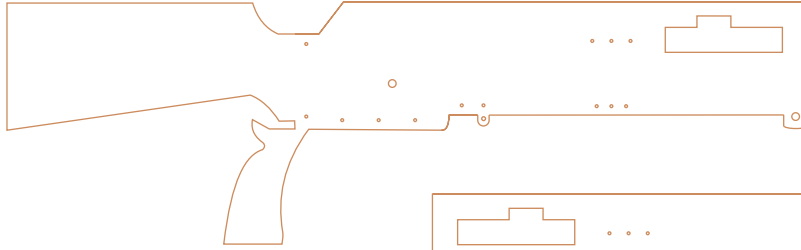

Left Side

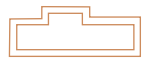
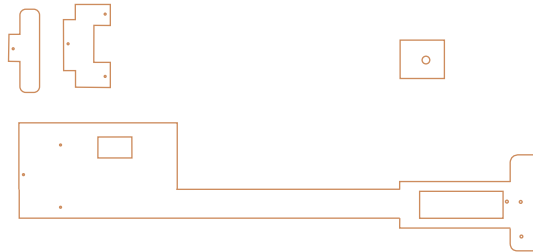
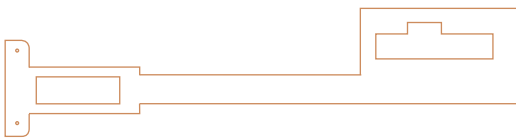
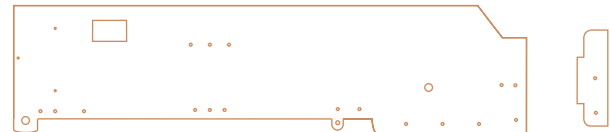
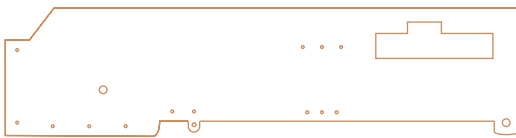
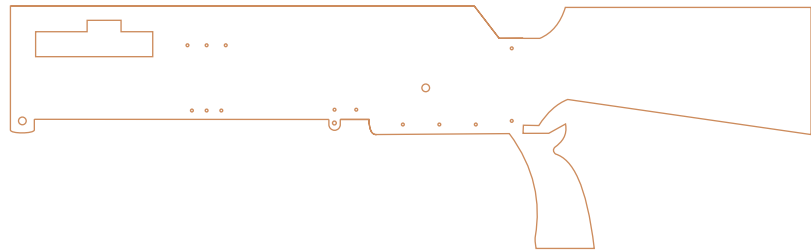

Bottom



Top

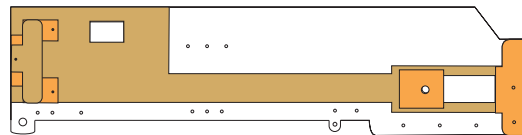
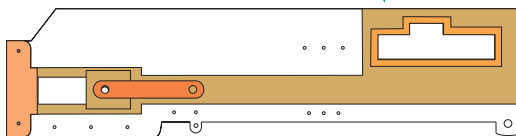

**Step 2**  
Assemble the Lock and Stock

Laminate all parts in order as shown in the diagram.

ASSEMBLY DRAWINGS SHOWN AT 1 / 6 SCALE

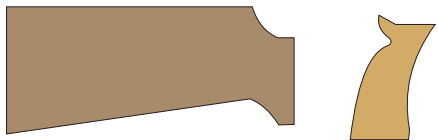
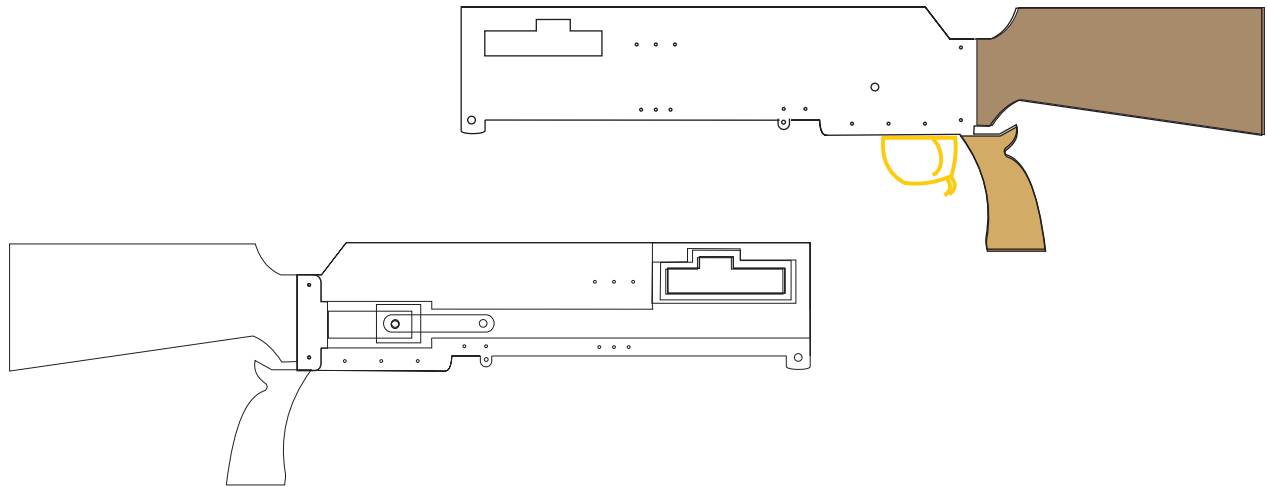

### Step 3

#### Assemble the Grips and Stock

Laminate all parts as shown in the diagram.  
Sand and seal all parts prior to painting.

### Step 4

#### Assemble the Trigger and Guard

1/6 Scale Size



1/5 Scale Size



1/4 Scale Size



1/3 Scale Size



Bend wire together as shown in the illustration to form the trigger and guard. Glue in place.

### Step 5

### Assemble the Feed Magazines.

Note that an extra drum and bracket are included as a spare for the gunner.

1

Assemble the two magazine drums.

Attach end of ammo belt.

Paper Tube

Cut to same width as inside opening on part

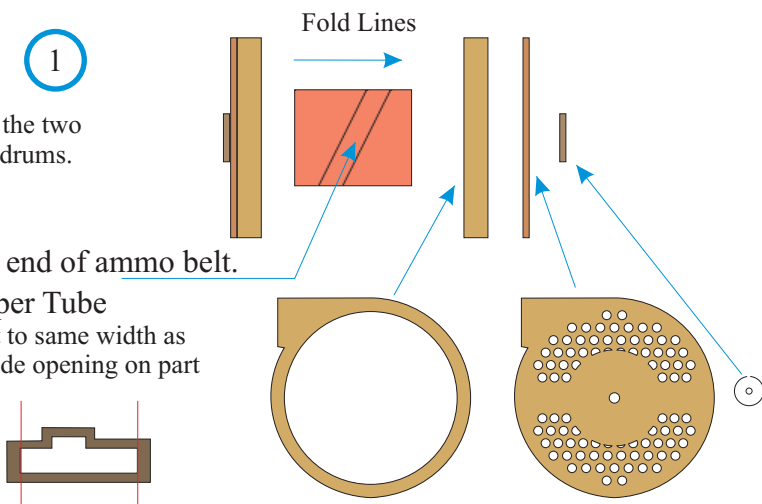

2

Wrap the outer cover around the drums.  
NOTE the starting spot, trim the opposite end of the cover as necessary to insert the ammunition and belt.

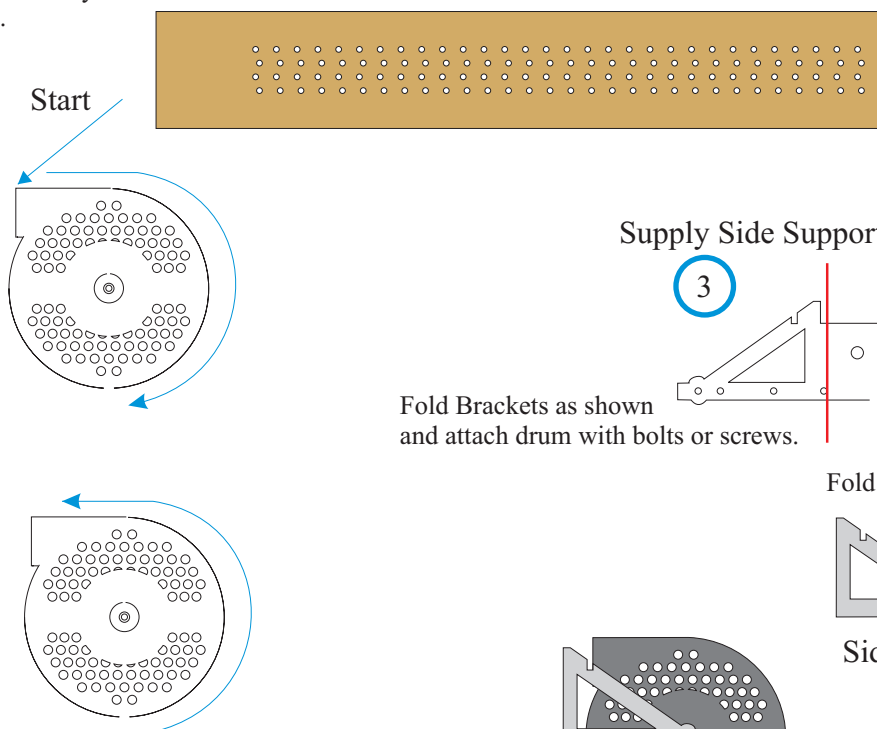

Supply Side Support Arm

3

Fold Brackets as shown and attach drum with bolts or screws.

Fold Lines

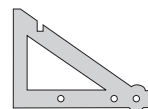

Side View

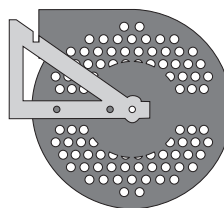

Be Sure to wrap the ammo belt in the proper direction. Remember to leave enough of the belt free to feed through the gun. ( see page 5)



### Flash Suppressor

Straight type: Make from scrap piece of tubing sized to fit over the barrel tube.

Or

Conical type: Cut from aluminum lithoplate and glue around barrel.

## Step 6

### Paint:

Finish the entire gun to a gun metal (dark gray) except the pistol grip and stock. These should be sanded smooth and stained to Rosewood or Mahogany and varnished.

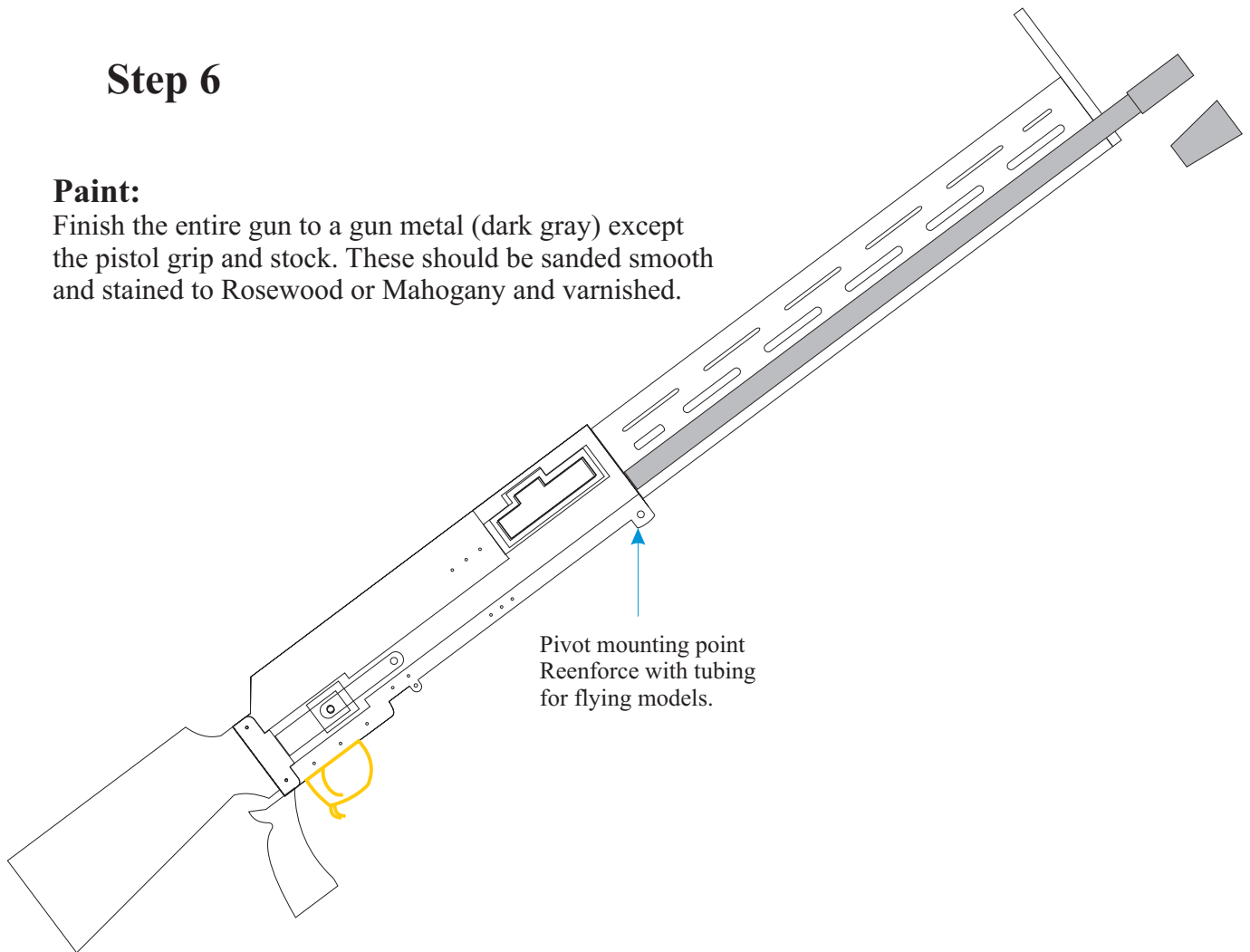

Pivot mounting point  
Reinforce with tubing  
for flying models.

### Magazine:

Attach one of the magazines to the right side of the gun at the shell port. Feed the ammo belt through the gun leaving about 3/8 to 1 / 2 inch of belt protruding from the other side.

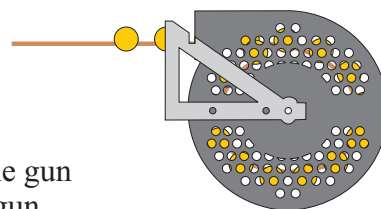



Copyright 2006 by

Arizona Model Aircrafters a registered tradename of  
Digital Design LLC 13814 N. 56th Place Scottsdale, AZ 85254